



PLB

FLEXIBLE PART LOCALIZATION FOR BIN PICKING AND DEPALLETIZING

Robot guidance systems / 3D machine vision

SICK
Sensor Intelligence.

FLEXIBLE AND PRECISE MATERIAL HANDLING

Companies in numerous industries are placing increasingly stringent requirements on sensors in order to be able to produce a wide variety of product variants and quantities on virtually any assembly line. Accordingly, there is a strong trend towards automated manufacturing right down to batch-size-one production. Without a doubt, material handling plays a significant role in flexible automation. SICK's PLB robot guidance system for bin picking and depalletizing has been designed with these requirements in mind. Thanks to its scalability, it offers best value for money.



EFFICIENT APPLICATIONS FOR ALL INDUSTRIES

The system can be used for a wide variety of applications in the following industries, amongst others: Automotive, machine tools, handling and assembly, retail and warehousing, as well as metal and steel.

Example applications



Depalletizing of parts

The PLB supports the robot-assisted picking of parts separated by slip sheets. The contrast-independent 3D images of the robot guidance system combined with the possibility to sort the parts according to the preferred picking sequence ensure easy depalletizing of parts.



Picking in the retail industry

PLB systems turn the picking of boxed items from totes and trays into child's play: Thanks to the used 3D camera with small- and medium field of view, the PLB optimally assists the robot in order commissioning.



Handling of items in production lines

To precisely localize forged and cast parts of irregular shape or in arbitrary orientation in large bins, the robot guidance system uses CAD drawings and compares these with the captured 3D images.

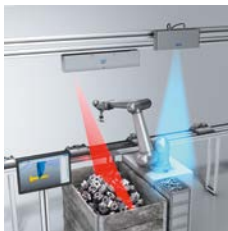

Kitting and assembly of components

The robot gripper assembles kits from various small parts for final assembly. This application can be implemented particularly economically using a PLB where several 3D cameras are connected to the localization software of the robot guidance system.



Loading of machines

Thanks to the high measurement accuracy of the PLB, it can be used to supply parts directly to the machine for processing. No additional equipment for orienting the parts is needed.

TAILORED BIN-PICKING SOLUTIONS

Components may have a wide variety of shapes and sizes and be sorted in a range of different ways – from simple contours to complex geometries, from high-speed handling of small parts in bulk storage to components sorted in layers. The PLB efficiently localizes components, verifies their position, and transfers the data to the robot.

Image acquisition using high quality 3D cameras

With a wide selection of camera types to choose from, the PLB is ideal for implementing tailored solutions. The laser-based triangulation variants ensure the lowest possible image noise, while the active illumination stereo cameras provide the highest image resolution. Configurations with multiple camera heads or rail mounted cameras are supported. The pre-calibrated systems provide data out of the box and can be easily exchanged by users.

+ High-performance cameras for the most demanding requirements



- Unaffected by ambient light conditions
- Insensitive to contrast and color variations
- Perfect combination of resolution and field of view

+ Camera configuration with customizable settings



- Several cameras can be connected to one computer
- One camera can cover several bins at the same time
- Different cameras, one software:
A robot can pick small and large parts in the same cell

IMAGE ACQUISITION

1



PLB500

Camera: Scanning Ruler
Types: Variant with laser triangulation and large field of view
Application: Localization of large parts

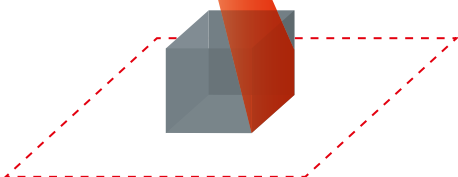

PLB520

Camera: X36
Types: Active illumination stereo camera with small, medium and large field of view
Application: Localization of small and large parts

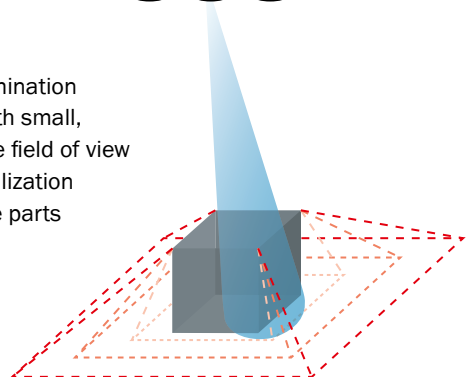

Reliable localization with collision detection thanks to sophisticated software

The PLB is equipped with software that can localize a wide variety of different parts by applying flexible algorithms to the recorded image data. The system not only delivers exact actual coordinates for robot guidance, but is also able to avoid collisions with the tote when positioning the gripper for part removal. No further programming is required. The PLB therefore offers a cost-efficient and user-friendly solution for system optimization.

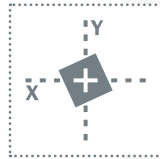

+ PLB algorithms for versatile localization tasks

- Suitable for a wide range of applications
- Easy teach-in of new parts at any time
- Simple configuration by graphical user interface: The user is guided through the configuration process

CAD matching

Ideal for localizing arbitrarily oriented or concealed parts within short cycle times. Parts are taught-in by entering CAD drawings. Delivers precise positioning data even at low image resolutions.

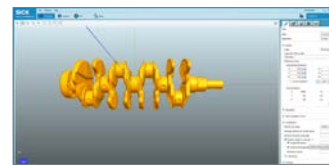

Geometrical matching

For fast and precise determining of the position of rectangular or cylindrical shaped components, and sorting all visible parts according to a defined picking sequence based on dimensional data. Parts are taught-in by entering dimensional data.



Edge matching

Suitable for parts of irregular shape and without pronounced surface variations. Localization occurs by means of part features such as edges and holes. An operator marks the relevant features on a reference image in the graphical user interface.

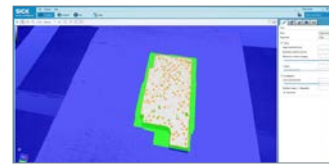

LOCALIZATION

2

3

DATA TRANSFER

Data transfer for seamless integration

The PLB can be very easily integrated into the robot controller. It reliably transfers data between the camera and robot thereby ensuring safe, trouble-free robot operation.

+ Interfaces for efficient processes

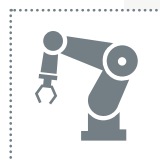

- Automated alignment of the PLB system and the robot coordinate system by means of robot program commands
- Configurable message formatting for interfacing to all Ethernet-capable robot models
- Data output supports all existing robot axis-rotation conventions

FLEXIBLE PART LOCALIZATION FOR BIN PICKING AND DEPALLETIZING

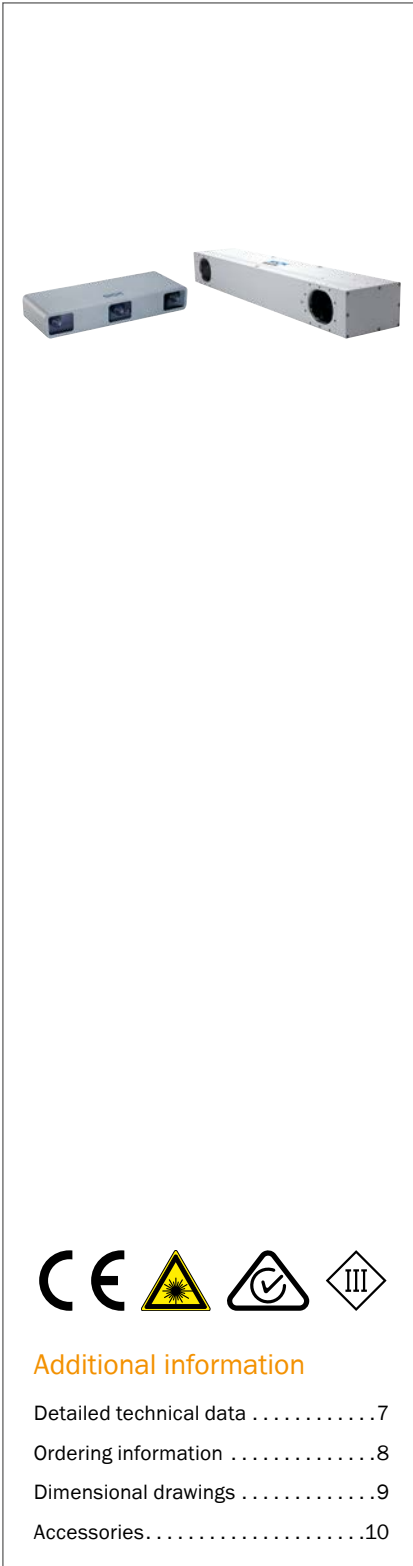

Product description

The PLB robot guidance system is designed for precise localization of parts stored in boxes or on pallets. The system is very flexible with a selection of 3D cameras to choose from. In combination with multiple localization algorithms, this ensures reliable operation in a large range of applications from small-part handling and depalletizing through to handling of large foundry parts. PLB sup-

ports easy configuration through a user interface tailored for part localization. It also includes functions to support simple integration with the robot controller, making it straightforward to integrate the system in production. Both the software and the pre-calibrated cameras are designed to be used right out of the box, so the system can be ready within minutes.

At a glance

- All functions tailored to target applications
- Several localization algorithms based on CAD and geometric part features
- Selection of various pre-calibrated 3D cameras for immediate use
- Thorough check for collision avoidance
- Easy integration with any robot model

Your benefits

- Easy-to-use system facilitating rapid design of new applications thanks to the tailored functions
- Selection of localization functions ensures reliable part-picking independent of the part's shape or orientation
- Range of 3D cameras ensures good image quality independent of part size
- System tailored for bin picking with collision avoidance and overlap detection ensure reliable robot operation and facilitate short robot picking cycle time
- Flexible robot integration functions makes it easy to use PLB together with any robot brand



Additional information

Detailed technical data	7
Ordering information	8
Dimensional drawings	9
Accessories	10

→ www.sick.com/PLB

For more information, simply enter the link or scan the QR code and get direct access to technical data, CAD design models, operating instructions, software, application examples, and much more.



Detailed technical data

The exact device specifications and performance data of the product may deviate from the information provided here, and depend on the application in which the product is being used and the relevant customer specifications.

General notes

	PLB500	PLB520-L	PLB520-M	PLB520-S
Items supplied	Scanning Ruler camera PLB Application Software	X36 camera PLB Application Software		

Features

	PLB500	PLB520-L	PLB520-M	PLB520-S
Industries	Automotive and parts suppliers Mobile automation Robotics Machine tools Handling and assembly technology Retail and warehousing			
Tasks	Position determination			
Camera type	3D snapshot			
Example volume of view (L x W x H)	800 mm x 1,200 mm x 1,000 mm (max. height range) 1,000 mm x 1,200 mm x 750 mm (max. image area)	1,300 mm x 1,200 mm x 1,000 mm	800 mm x 600 mm x 400 mm	400 mm x 300 mm x 200 mm
Image resolution	1 mm ... 4 mm, depending on distance to camera	1 mm ... 1.7 mm, depending on the distance to the camera	0.7 mm ... 0.8 mm, depending on the distance to the camera	0.4 mm ... 0.5 mm, depending on the distance to the camera
Light source	Laser, red, 660 nm, ± 15 nm	LED, blue, 465 nm		
Laser class	2	-		
LED class	-	Risk group 1		
3D CAD format	IGES, STEP			
Localization principle	CAD-model, geometrical shape and edge localization			

Performance

	PLB500	PLB520-L	PLB520-M	PLB520-S
Part localization time	5 s ... 10 s (typical)	3 s ... 10 s (typical)		
Part localization accuracy	< +/- 2 mm and < +/- 1° (typical)	< +/- 1 mm and < +/- 1° (typical)	< +/- 0.7 mm and < +/- 0.7° (typical)	< +/- 0.5 mm and < +/- 0.5° (typical)
Part size	(approx.) > 100 mm x 100 mm x 100 mm	(approx.) > 50 mm x 50 mm x 50 mm	(approx.) > 30 mm x 30 mm x 30 mm	(approx.) > 15 mm x 15 mm x 15 mm
Part characteristics	Simple and complex part shapes			

Interfaces

	PLB500	PLB520-L	PLB520-M	PLB520-S
Ethernet	✓ (2), camera <--> PC, PC<--> robot			
Data transmission rate	1 Gbit/s (camera), 10/100 Mbit/s (robot)			
Protocol	UDP/IP (camera), TCP/IP (robot)			
Electrical connection	RJ45	M12 male connector, 8-pin, x-coded		

	PLB500	PLB520-L	PLB520-M	PLB520-S
Supply voltage	✓			
Electrical connection	Male connector M12, 8-pin	Male connector M12, 4-pin		

Mechanics/electronics

	PLB500	PLB520-L	PLB520-M	PLB520-S
Supply voltage ¹⁾	24 V DC,			
Current consumption	1 A	5 A		
Dimensions, system (L x W x H)	820 mm x 107 mm x 145 mm	488 mm x 180 mm x 80 mm		
Weight	13.5 kg	2.5 kg		
Enclosure rating	IP65	IP54		

¹⁾ ± 15 %.

Ambient data

	PLB500	PLB520-L	PLB520-M	PLB520-S
Ambient operating temperature	0 °C ... +40 °C, Non-condensing			
Shock load	15 g, 3 x 6 directions ¹⁾	80 g/1,9 ms, 25 g / 6 ms ²⁾		
Vibration load	5 g (58 Hz ... 150 Hz)	30-500 Hz / 10 g ³⁾		

¹⁾ Not during scanning.

²⁾ IEC 60068-2-27.

³⁾ IEC 60068-2-6.

Ordering information

Field of view	Image resolution	Type	Part no.
800 mm x 1,200 mm x 1,000 mm (max. height range), 1,000 mm x 1,200 mm x 750 mm (max. image area)	1 mm ... 4 mm, depending on distance to camera	PLB500	1058009
1,300 mm x 1,200 mm x 1,000 mm	1 mm ... 1.7 mm, depending on the distance to the camera	PLB520-L	1098446
800 mm x 600 mm x 400 mm	0.7 mm ... 0.8 mm, depending on the distance to the camera	PLB520-M	1098448
400 mm x 300 mm x 200 mm	0.4 mm ... 0.5 mm, depending on the distance to the camera	PLB520-S	1098450

Dimensional drawings (Dimensions in mm (inch))

Scanning Ruler

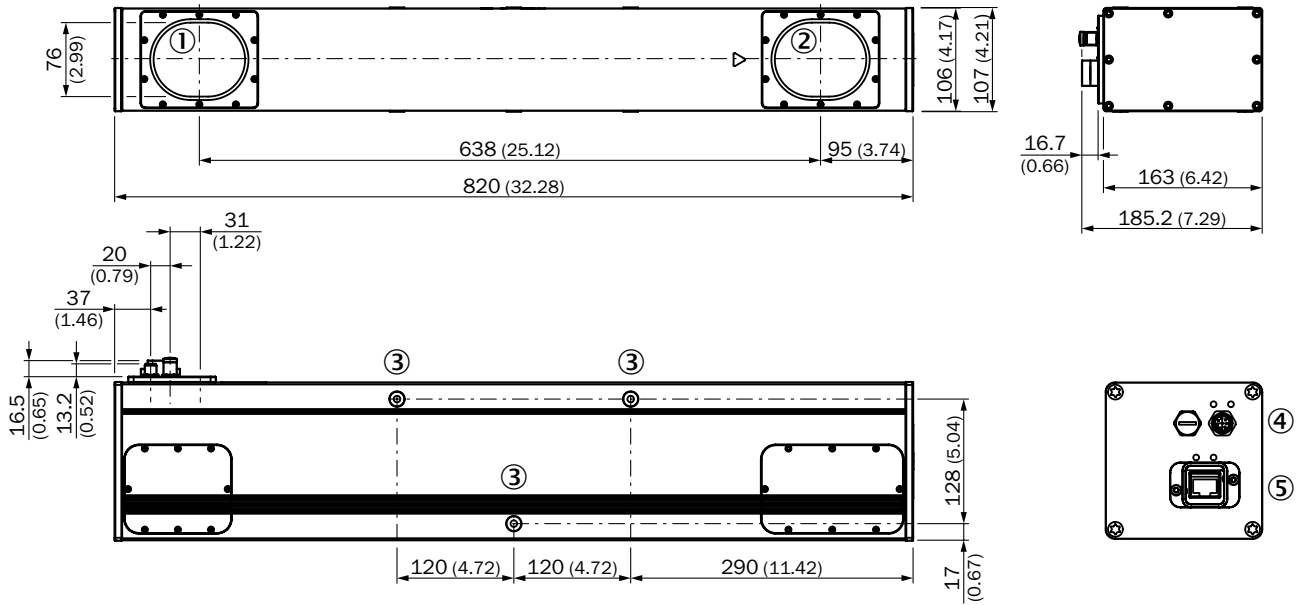

- ① Image sensor
- ② Laser unit and rotating mirror
- ③ Fastening threads (M8 x 15 mm)
- ④ Power I/O: M12, 8-pin
- ⑤ Gigabit Ethernet

X36 Camera

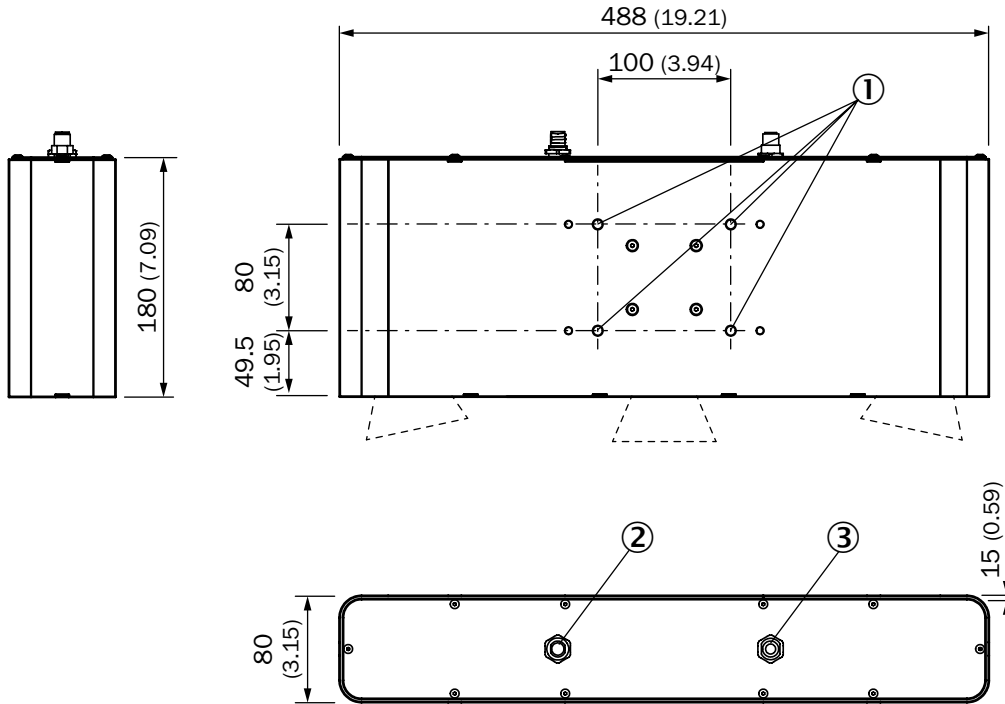

- ① Mounting hole patter M8x4
- ② Ethernet connector M12
- ③ Power I/O connector M12





Accessories

Connection systems

Power supply units and power supply cables

Figure	Brief description	Type	Part no.	PLB500	PLB520-L	PLB520-M	PLB520-S
	Power supply unit	Power supply unit	6032863	●	●	●	●

Plug connectors and cables

Figure	Brief description	Length of cable	Type	Part no.	PLB500	PLB520-L	PLB520-M	PLB520-S
	Head A: female connector, M12, 8-pin, straight Head B: Flying leads Cable: PVC, shielded, 7.7 mm Details	10 m	DOL-1208-G10MA	6022152	●	-	-	-
	Head A: female connector, M12, 4-pin, straight, A-coded Head B: Flying leads Cable: Sensor/actuator cable, PUR, halogen-free, shielded, 0.34 mm ² , 5.3 mm Details	10 m	YF2A24-100UB4X-LEAX	2095730	-	●	●	●
	Head A: male connector, PushPull Head B: male connector, RJ45 Cable: Gigabit Ethernet, unshielded Details CAT6	10 m	SSL-0J08-G10ME	6032322	●	-	-	-
	Head A: male connector, M12, 8-pin, straight, X-coded Head B: male connector, RJ45, 8-pin, straight Cable: Gigabit Ethernet, twisted pair, PUR, halogen-free, shielded, 4 x 2 x 0.14 mm ² , 6.4 mm, AWG26 Details	10 m	YM2X18-100EG2M-RJA8	6049730	-	●	●	●

Further accessories

Calibration tools

Figure	Brief description	Type	Part no.	PLB500	PLB520-L	PLB520-M	PLB520-S
	Tool for aligning the PLB coordinate system with the robot	Alignment aid for PLB	2084680	●	●	●	●

REGISTER AT WWW.SICK.COM TO TAKE ADVANTAGE OF OUR FOLLOWING SERVICES FOR YOU





- ✔ Access information on net prices and individual discounts.
- ✔ Easily order online and track your delivery.
- ✔ Check your history of all your orders and quotes.
- ✔ Create, save, and share as many wish lists as you want.
- ✔ Use the direct order to quickly order a big amount of products.
- ✔ Check the status of your orders and quotes and get information on status changes by e-mail.
- ✔ Save time by using past orders.
- ✔ Easily export orders and quotes, suited to your systems.



SERVICES FOR MACHINES AND PLANTS: SICK LifeTime Services

Our comprehensive and versatile LifeTime Services are the perfect addition to the comprehensive range of products from SICK. The services range from product-independent consulting to traditional product services.



- 
Consulting and design
 Safe and professional
- 
Product and system support
 Reliable, fast, and on-site
- 
Verification and optimization
 Safe and regularly inspected
- 
Upgrade and retrofits
 Easy, safe, and economical
- 
Training and education
 Practical, focused, and professional

SICK AT A GLANCE

SICK is a leading manufacturer of intelligent sensors and sensor solutions for industrial applications. With more than 9,700 employees and over 50 subsidiaries and equity investments as well as numerous agencies worldwide, SICK is always close to its customers. A unique range of products and services creates the perfect basis for controlling processes securely and efficiently, protecting individuals from accidents, and preventing damage to the environment.

SICK has extensive experience in various industries and understands their processes and requirements. With intelligent sensors, SICK delivers exactly what the customers need. In application centers in Europe, Asia, and North America, system solutions are tested and optimized in accordance with customer specifications. All this makes SICK a reliable supplier and development partner.

Comprehensive services round out the offering: SICK LifeTime Services provide support throughout the machine life cycle and ensure safety and productivity.

That is “Sensor Intelligence.”

Worldwide presence:

Australia, Austria, Belgium, Brazil, Canada, Chile, China, Czech Republic, Denmark, Finland, France, Germany, Great Britain, Hungary, Hong Kong, India, Israel, Italy, Japan, Malaysia, Mexico, Netherlands, New Zealand, Norway, Poland, Romania, Russia, Singapore, Slovakia, Slovenia, South Africa, South Korea, Spain, Sweden, Switzerland, Taiwan, Thailand, Turkey, United Arab Emirates, USA, Vietnam.

Detailed addresses and further locations → www.sick.com